

Räumzahn-Wälzfräser für Evolventenverzahnungen

Heavy duty roughing hobs for involute gear forms

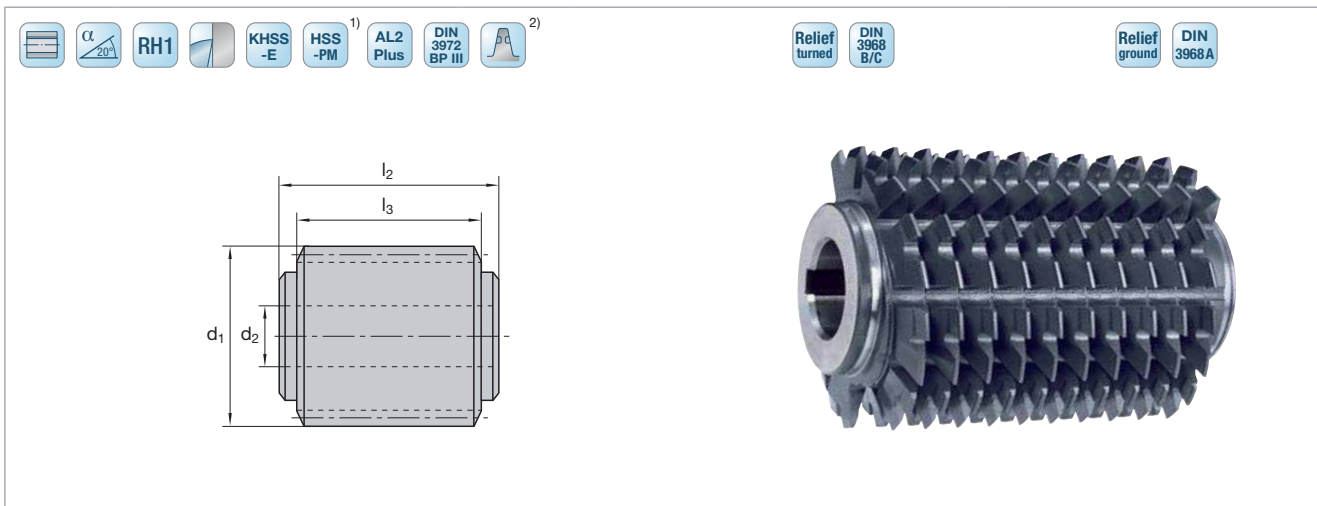

Katalog-Nr. Cat.-No.						2061	2063
m	d ₁	l ₃	l ₁	d ₂	z	Ident No.	Ident No.
6	150	108	118	50	20	1208017	1208053
7	150	126	136	50	20	1208019	1208055
8	160	144	154	50	20	1208021	1208057
9	160	162	172	50	20	1208023	1208059
10	170	180	190	60	20	1208025	1208061
11	180	198	208	60	20	1208027	1208063
12	190	216	226	60	20	1208029	1208065
13	200	234	244	60	20	1208031	1208067
14	210	252	262	60	20	1208033	1208069
15	230	270	280	80	20	1208035	1208071
16	240	288	300	80	20	1208037	1208073
18	260	318	330	80	20	1208039	1208075
20 ³⁾	287	318	330	80	20	1208041	1208077
20	290	360	372	100	20	1208043	1208079
22	300	396	408	100	20	1208045	1208081
24	310	432	444	100	20	1208047	1208083
27	330	486	498	100	20	1208049	1208085
30	340	540	552	100	20	1208051	1208087

¹⁾ auf Anfrage
on request

²⁾ wahlweise
optionally

³⁾ für Wälzfräsmaschinen mit max. Durchlass – Ø 290 mm und für Fräserlänge = 330 mm
for hobbing machines with max. capacity = 290 mm dia. and for max. cutter length = 330 mm