

Wälzfräser für Evolventenverzahnungen Hobs for involute gear forms

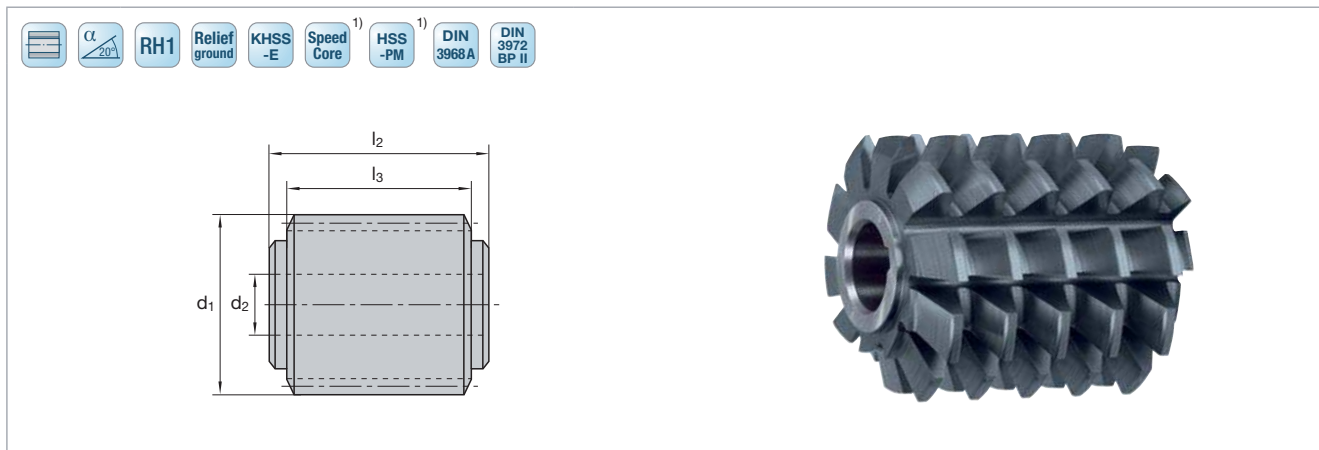

Katalog-Nr. Cat.-No.						2032
m	d ₁	l ₃	l ₁	d ₂	z	Ident No.
1	50	25	31	22	14	1205165
1,25	50	25	31	22	14	1205174
1,5	56	32	38	22	12	1205183
1,75	56	32	38	22	12	1205192
2	63	40	46	27	12	1205209
2,25	70	50	56	27	12	1205218
2,5	70	50	56	27	12	1205227
2,75	70	50	56	27	12	1205236
3	80	63	69	32	12	1205245
3,25	80	63	69	32	12	1205254
3,5	80	63	69	32	12	1205263
3,75	90	70	78	32	12	1205272
4	90	70	78	32	12	1205281
4,5	90	70	78	32	10	1205290
5	100	80	88	32	10	1205307
5,5	100	80	88	32	10	1205316
6	115	100	108	40	10	1205325
6,5	115	100	108	40	10	1205334
7	115	100	108	40	10	1205343
8	125	130	138	40	10	1205352
9	125	130	138	40	10	1205361
10	140	160	170	40	10	1205370
11	160	170	180	50	9	1205389
12	170	185	195	50	9	1205398
13	180	200	210	50	9	1205405
14	190	215	225	50	9	1205414
15	200	225	235	60	9	1205423
16	210	238	248	60	9	1205432
17	220	238	248	60	9	2264410
18	230	260	270	60	9	1205450
19	240	260	270	60	9	1203986
20	250	286	296	60	9	1205478
21	260	290	300	60	9	1203988
22	270	290	300	60	9	2105475
23	280	310	320	60	9	1203990
24	280	310	320	60	9	2107384
25	290	320	330	60	9	2117926
26	310	320	330	80	9	2251168
27	320	330	340	80	9	1203992
28	320	330	340	80	9	1203994
29	340	340	350	80	9	1203996
30	340	340	350	80	9	2117930

¹⁾ auf Anfrage on request

Beschichtungen auf Anfrage Coatings on request