

Schaftfräser, Einschnneider

End mill, single flute

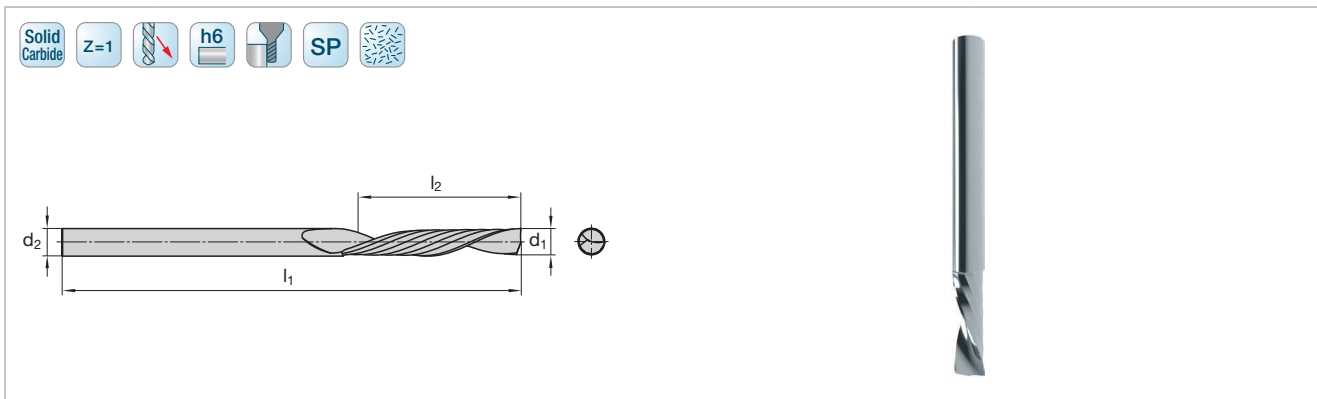

Katalog-Nr. Cat.-No.				12000		
d ₁	l ₂	d ₂	l ₁	LMT-Code	Ident No.	
mm						
1	4	3	30	12010	2700279	
1,5	6	3	30	12015	2700281	
2	8	2	30	12020	2700025	
2	8	2	60	12020A	2701844	
2	8	3	30	12020B	2700282	
2,5	8	2,5	30	12025	2700254	
2,5	8	2,5	60	12025A	2701846	
3	10	3	30	12030	2703050	
3	10	3	60	12030A	2701847	
3	10	6	50	12030B	2700283	
4	12	4	50	12040	2700256	
4	20	4	60	12040A	2701849	
4	30	4	70	12040B	2701850	
4	12	6	50	12040C	2700284	
5	16	5	60	12050	2700257	
5	30	5	70	12050A	2701852	
5	16	6	50	12050B	2700285	
6	20	6	60	12060	2700258	
6	30	6	70	12060A	2701843	
6	38	6	80	12060B	2701841	
8	22	8	60	12080	2700259	
8	38	8	80	12080A	2701854	
10	30	10	75	12100	2700260	
12	30	12	75	12120	2700261	
inch						
0.125	0.500	0.250	1.500	12317	2701848	
0.188	0.625	0.250	2	12476	2701851	
0.250	0.750	0.250	2	12635	2701853	

Auf Anfrage: Beschichtung

On request: Coating

Einsatzempfehlungen siehe Seiten 6–10

Application recommendations see pages 6–10